

TELESIS TCS

Thermoplastic Low-Profile LED Emergency Light

The Telesis TCS provides high performance LED lamps in an economical contemporary housing that complements most interior applications. The TCS is engineered for Quick fit easy installation, maintenance free reliability and is also available for wet locations (see TCSWL spec sheet).



CONSTRUCTION

- Compact low profile design
- High impact injection molded thermoplastic, 5VA rated flame retardant ABS housing available in white or black finish
- Snap fit housing for easy installation
- Knockout Universal mounting pattern for wall mounting
- Knockout for top conduit entry

ELECTRICAL

- Fully automatic operation turns on the emergency lamps on failure of normal power and automatically recharges the battery on restoration of normal power
- 6V Maintenance free rechargeable Lead Calcium battery
- 7 watt LED lamps provide 90 minute operation
- Field selectable 120 or 277VAC input
- Operating temperature range is 20° to 40° C
- Constant voltage two rate charger recharges the battery in 24 hours
- Momentary test switch and AC on indicator
- Line latch prevents unnecessary discharge of battery during installation, loads will not illuminate until after application of utility power
- Low voltage cut-off prevents battery damage and ensures positive charge acceptance following an extensive discharge
- Brownout sensing assures emergency operation during periods of low line voltage
- Damp location environmentally coated circuitry as standard

ILLUMINATION

- Two fully adjustable low profile 7 Watt LED lampheads are standard
- 7 Watt LED lamps provide 517 Lumens each

CERTIFICATION

- Meets UL924, NFPA 101 Life Safety Code, NFPA 70-NEC, and OSHA requirements
- UL924 listed for damp location 20° to 40°C

WARRANTY

- 5 year limited warranty- view complete warranty terms online at www.evenlite.com/terms-warranty.

DIMENSIONS

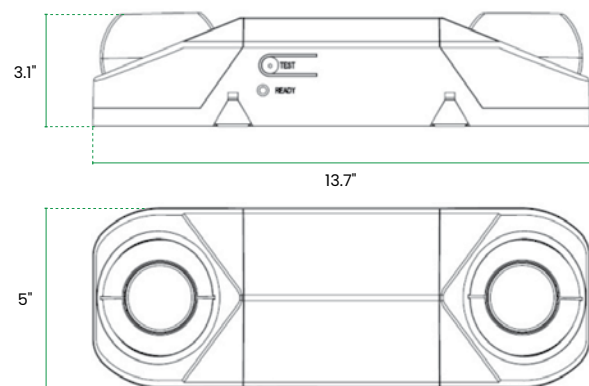

TCS-W-L67-US

ORDERING GUIDE

MODEL	HOUSING COLOR	LAMPHEADS	OPTIONS
TCS	W White	L67 6V 7W LED	US Assembled in the USA
	B Black		VRS Polycarbonate Vandal Shield
TCS		L67	SD Self-Test/Self-Diagnostics

Fill in fields from categories above and complete type and part number.

Type No:

Full Part No: