

DÉCOR DESIGNER DR

Recessed LED Emergency Light

The Décor Designer DR series provides an injection-molded, engineering grade thermoplastic housing, compatible with drop ceiling mount installations. The internal solid-state transfer switch automatically connects the internal battery to lampheads for minimum 90-minute emergency illumination.



CONSTRUCTION

- Recessed mount includes hanger bars
- Compatible with drop ceiling mount installations
- Injection-molded, engineering grade, 5VA flame-retardant, impact-resistant, thermoplastic housing in white or black finish
- Thermoplastic Oval and Rectangle trim plates in white or black finish included

ELECTRICAL

- Dual 120 / 277 voltage
- Charge rate / power "ON" LED indicator light and push-to-test switch for mandated code compliance testing
- 4.8V maintenance-free, rechargeable Ni-MH battery
- Internal solid-state transfer switch automatically connects the internal battery to lampheads for minimum 90-minute emergency illumination
- Self-diagnostic feature performs monthly, bi-annual, and annual tests to ensure reliable operation and meet electrical and life safety codes
- Fully automatic solid-state, two rate charger recharges discharged batteries within 24 hours

ILLUMINATION

- Long lasting, efficient, ultra-bright white LED lampheads
- 4 Watts (4 X 1W LED lampheads)
- Unique all-inclusive lamp, reflector and lens assembly
- Adjustable LED lampheads provide up to 50-ft center-to-center spacing

CERTIFICATION

- Meets UL924, NFPA 101 Life Safety Code, NEC, OSHA, Local and State Codes
- UL Listed for damp locations (10°C to 40°C)
- Certified to CEC under title 20 regulations

WARRANTY

- 5 year warranty on electronics and housing- view complete warranty terms online at www.evenlite.com/terms-warranty.
- 1 year full, 4 year prorated on battery

ORDERING GUIDE

DR-W-SD

MODEL	HOUSING COLOR	OPTIONS
DR	W White	SD Self-Test / Self-Diagnostic
	B Black	
DR		

Fill in fields from categories above and complete type and part number.

Type No:	Full Part No:
----------	---------------

DIMENSIONS

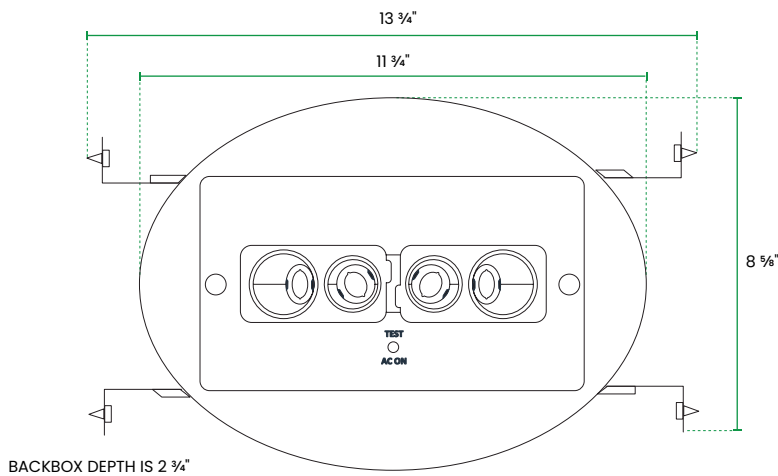
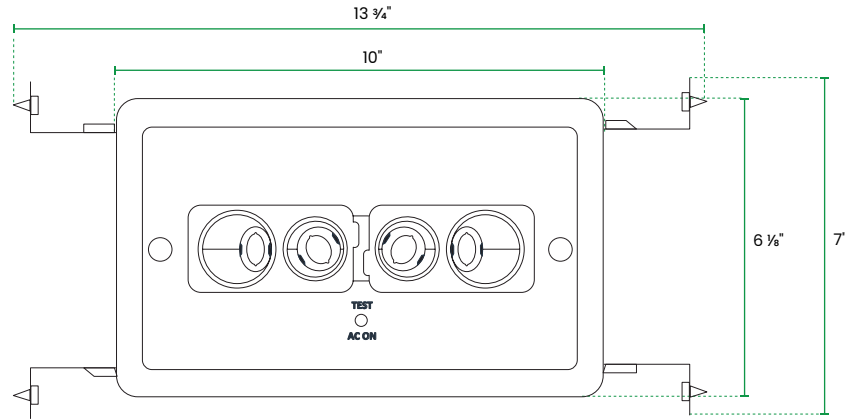

SPACING GUIDE

MOUNT HEIGHT	3FT WIDTH EGRESS PATH		6FT WIDTH EGRESS PATH	
	SINGLE FIXTURE	FIXTURE TO FIXTURE	SINGLE FIXTURE	FIXTURE TO FIXTURE
10'	50'	50'	40'	43'
12'	50'	50'	40'	43'
15'	40'	42'	30'	38'

